

HYDRAULIC POWER UNITS

L STYLE TANK

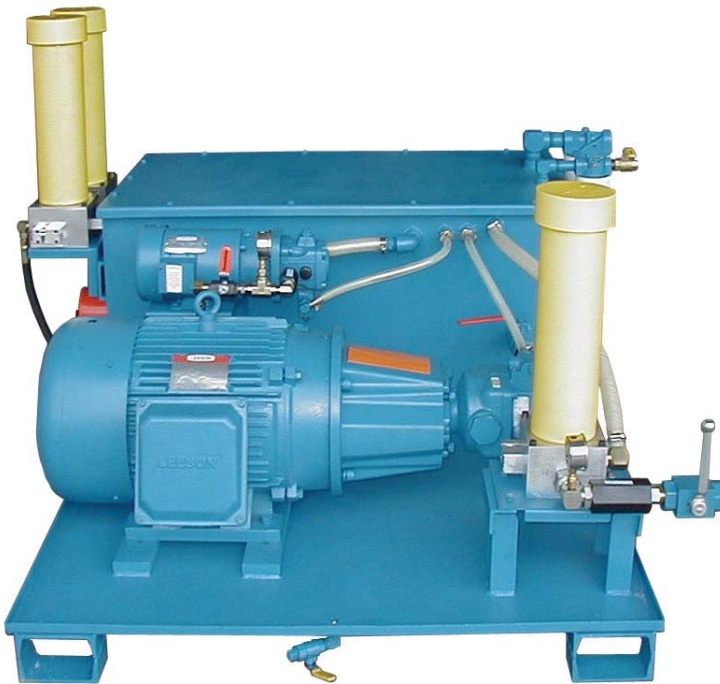

LT100 "L" Tank

Features

LT Series

- Lower Profile:** Unit can be mounted under work tables, conveyors, etc. Easy access to pump and motor.
- Flooded Suction:** Longer pump life; pump always stays primed. No pump rusting during shut-down periods. Air bleed valves are not required.
- Easy Reservoir Draining:** Pump not required for draining. Drain ball valve provided.
- Self Flushing:** System flushes any material in suction line when a pump is replaced.
- Color Code Identification:** Allows for easy identification of items.
- In-Tank Filter System:** Provides easy element replacement without line drainage.
- Convenient Suction Strainer Maintenance:** Clean out access cover allows replacement of suction strainer without draining reservoir.
- Removable Top Plate:** Removable top allows for easy reservoir cleaning. No leaky end bells that make access for cleaning difficult.
- Integral Drip Pan:** Pump/ motor mounting area serves as drip pan- drain ball valve included standard.

ITEM IDENTIFICATION:

- CLEAN-OUT COVER (YELLOW)
- VALVE MOUNTING AREA
- RETURN FILTER (YELLOW)
- TANK LID
- RUBBERIZED GASKET
- TANK BODY
- FILLER/ BREATHER
- SIGHT & TEMPERATURE GAUGE
- SUCTION STRAINER WITH BYPASS VALVE
- 1/2" NPT DRAIN BALL VALVE WITH PLUG
- MAGNETS (1 PER 5 GALLONS)
- (3) RETURN COUPLINGS STANDARD
- 2" NPT HEATER COUPLING (OPTIONAL)
- SUCTION BALL VALVE
- PUMP
- PUMP MOTOR ADAPTER (ORANGE)
- ELECTRIC MOTOR
- PRESSURE GAUGE WITH SNUBBER
- FILTER INDICATOR GAUGE (OPTIONAL)
- HEATER (OPTIONAL)
- HEAT EXCHANGER (OPTIONAL)
- COOLING FAN (OPTIONAL)
- PAINT (OPTIONAL)**

COLOR CODES:
 BLUE- UNIT COLOR PAINT
 ORANGE- DANGER
 YELLOW- MAINTENANCE
 GRAY- ELECTRICAL

Dimensional Data

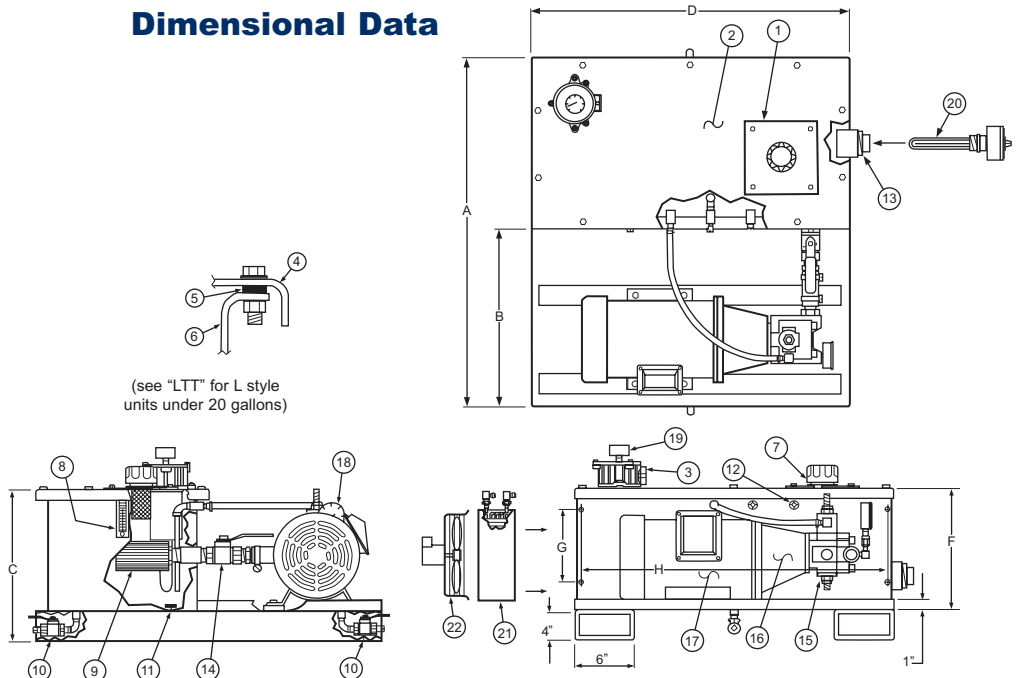

Model Number	Reservoir Capacity	Dimensions (Inches)								Std. Return Filter (10 μ)	Maximum Horsepower
		A	B	C	D	E	F	G	H		
LT20	20 Gallon	35.0	17.5	15.4	32.0	12.0	12.0	8	30.6	ITF200-8FS-10MNPE	5
LT35	35 Gallon	45.0	22.5	17.5	36.5	13.5	13.5	8	35.3	ITF200-12FS-10MNPE	15
LT70	70 Gallon	51.6	26.3	20.5	46.5	16.5	16.5	8	45.3	ITF250-12FS-10MNPE	50
LT100	100 Gallon	51.6	26.3	26.0	46.5	22.0	22.0	8	45.3	ITF425-24FS-10MNPE	100
LT150	150 Gallon	51.6	26.3	38.0	46.5	33.0	34.0	8	45.3	ITF450-24FS-20-10	100
LT200	200 Gallon	72.0	36.0	38.0	48.5	37.5	34.0			ITF450-24FS-30-10	150
LT500	500 Gallon	92.6	46.3	41.5	71.0	37.5	37.0			ITF450-24FS-30-10	150



HYDRAULIC POWER UNITS

L STYLE TANK



LT & LTT Series

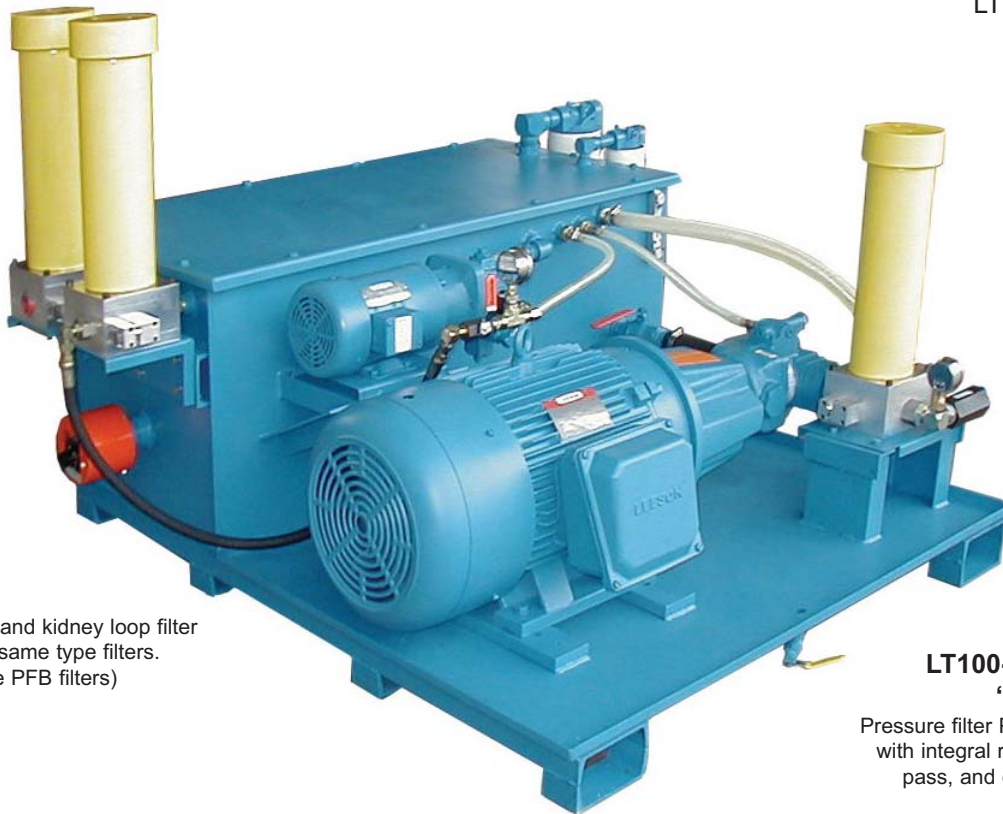

Return filter and kidney loop filter
utilizing same type filters.
(see PFB filters)

LT100-40HP-PCP30 "L" Tank:

Pressure filter PFB100-20FS-18.6-3-D1
with integral relief, integral 70 psi by
pass, and differential indicator:

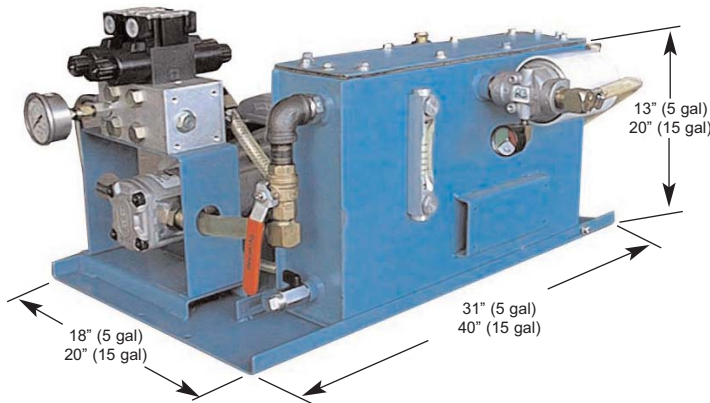

LTT "L" Tank Tall

LTT5, 5 gallon tank dimensions:
5" w x 21" l x 12.8" h

LTT15, 15 gallon tank dimensions:
7" w x 32" l x 17.8" h



LTT "L" Tank
Tall- Welded
(Completely sealed
reservoir versions
available)

