



Fluid Power Pneumatic Division

AIR PILOTED VALVES

200 THRU 800 SERIES

1/8" - 1/2" Ports



Air Piloted Valves 1/8" - 1/2" ports

SPECIFICATIONS

| | | | |
|-----------------------|----------------------------------|----------------------------------|--------|
| Media | Air (No other gases or liquids) | | |
| Operation | Direct Air Pilot | | |
| Operating Temp. Range | 41 - 140°F (5 - 60°C) | | |
| Maximum Pressure | 135psig (9.3 bar) | | |
| Working Pressure | 20-100 psig (1.4-6.9 bar) | | |
| Flows | Two Position | Three Position (spring centered) | |
| | AV-202 (1/8") | Cv=0.7 | Cv=0.6 |
| | AV-204 (1/4") | Cv=0.8 | Cv=0.6 |
| | AV-404 (1/4") | Cv=1.4 | Cv=1.0 |
| | AV-406 (3/8") | Cv=1.6 | Cv=1.0 |
| AV-808 (1/2") | Cv=2.7 | Cv=1.6 | |
| Lubrication | None Required | | |
| Maximum Response Time | Pilot 30ms @80 psi/ Spring- 50ms | | |
| Maximum Cycle Rate: | | | |
| | Series 200 | 5 cycles/second | |
| | Series 400 | 4 cycles/second | |
| | Series 800 | 3 cycles/second | |

DIMENSIONAL DATA

Units: mm/ (Inch)

200 SERIES 1/8", 1/4"

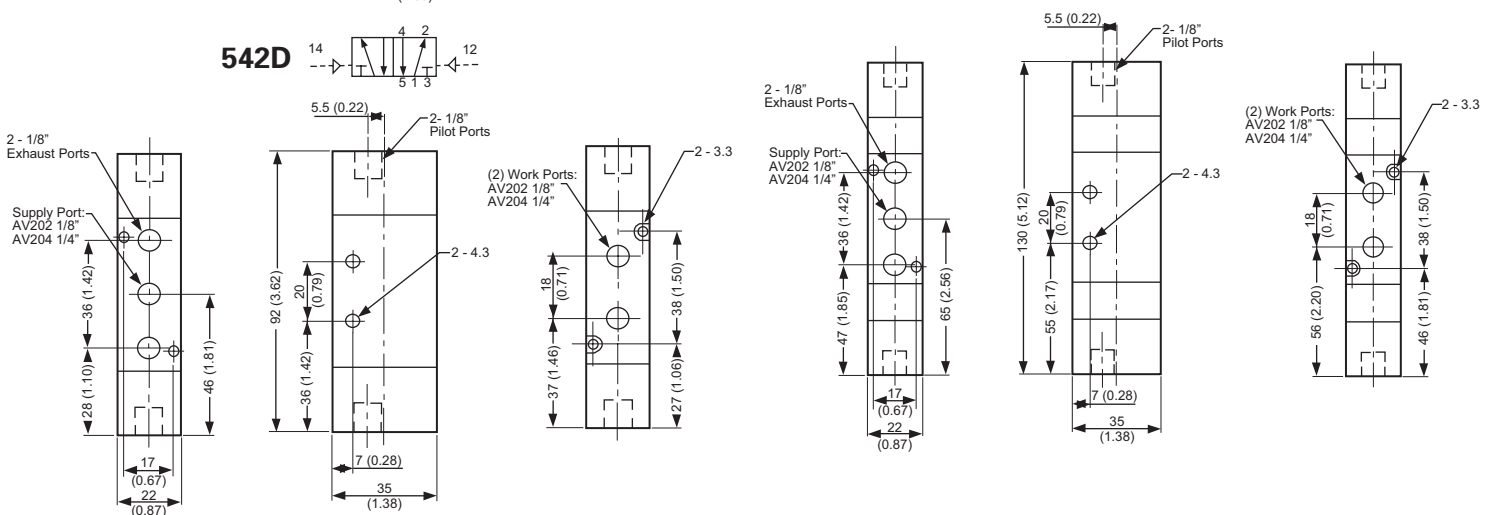
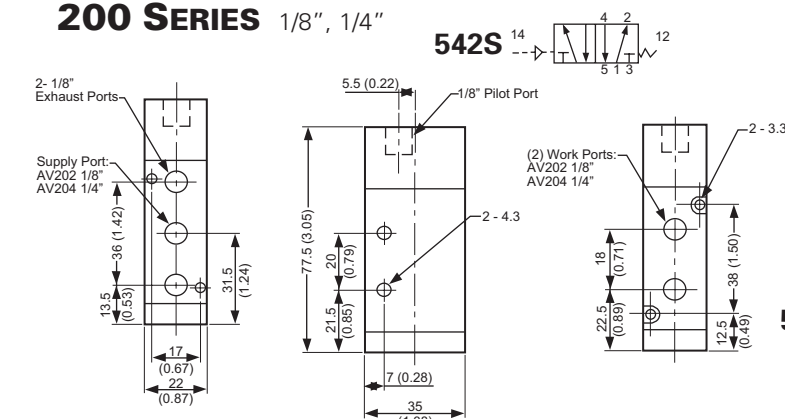

FEATURES

- Available: 1/8", 1/4", 3/8", and 1/2" ports.
- All 4-way valves may be manifold mounted.
- U-cup type seals allow low shifting pressures and avoid sticking.
- Anodized aluminum spools.
- Same base valve also available as SV series, solenoid valve.
- Dual porting available in 200/400 series.



Fluid Power Pneumatic Division

AIR PILOTED VALVES

200 THRU 800 SERIES

1/8" - 1/2" Ports

DIMENSIONAL DATA

Units: mm/ (Inch)

400 SERIES 1/4", 3/8"

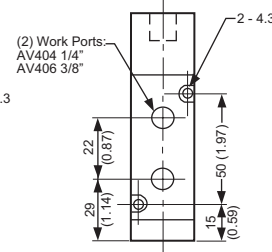
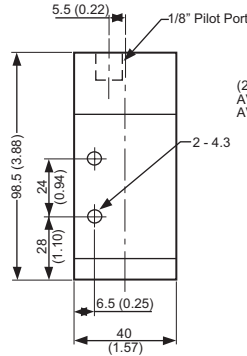
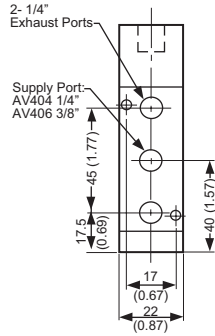
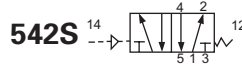

AV404
AV406

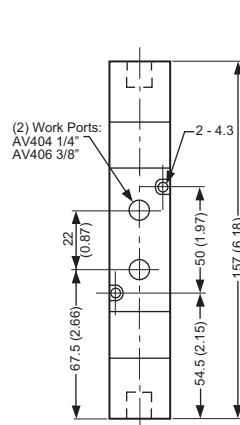
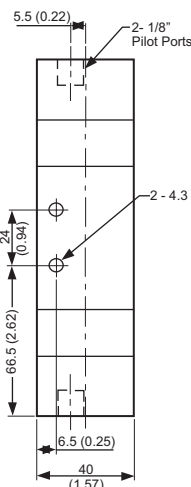
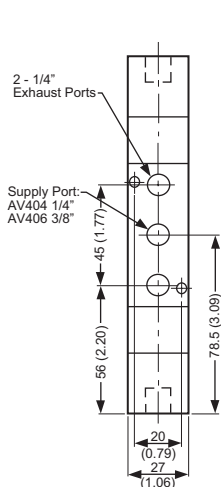
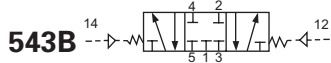
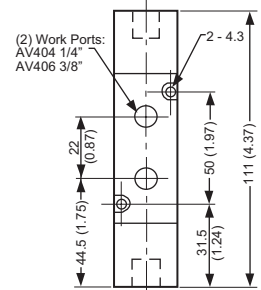
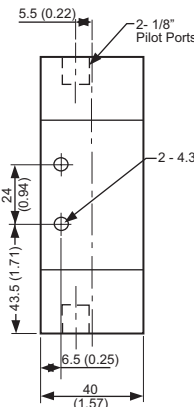
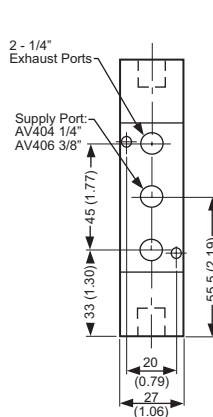
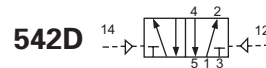



Fluid Power Pneumatic Division

AIR PILOTED VALVES

200 THRU 800 SERIES

1/8" - 1/2" Ports

DIMENSIONAL DATA

Units: mm/ (Inch)

800 SERIES 1/2"

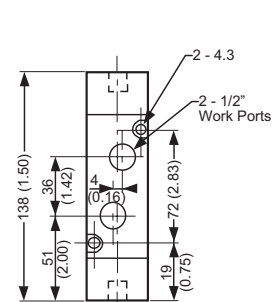
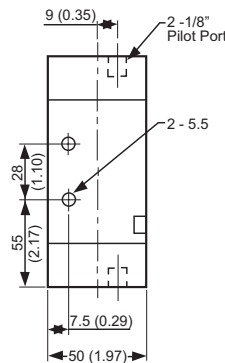
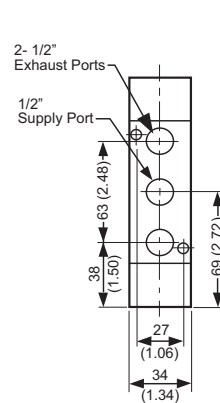
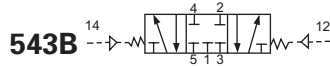
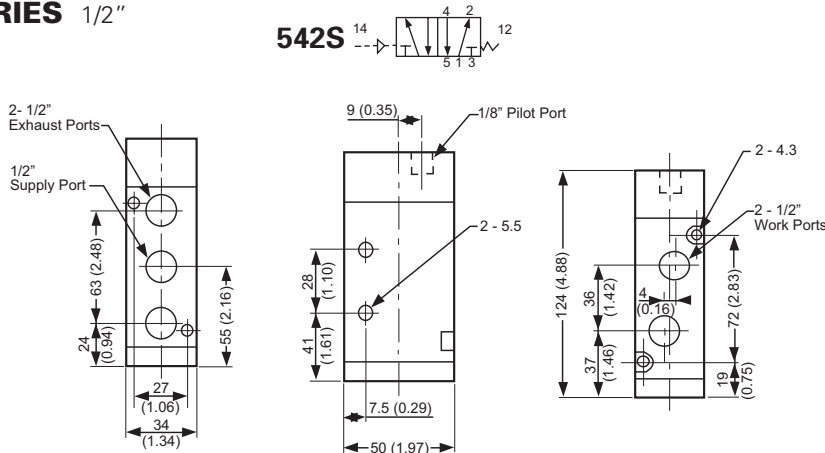

ORDERING INFORMATION

AV - 404 - 542S

| Code | Description |
|------|-------------------|
| AV | Air Piloted Valve |

| Size | Description |
|------|---------------------------|
| 202 | 1/8" Ports |
| 204 | 1/4" Ports (1/8" Exhaust) |
| 404 | 1/4" Ports |
| 406 | 3/8" Ports (1/4" Exhaust) |
| 808 | 1/2" Ports |

| Code | Configurations |
|------|--|
| 542S | 5 port, 4 way, 2 pos., spring return (single pilot) |
| 542D | 5 port, 4 way, 2 pos., detented double pilot |
| 543B | 5 port, 4 way, 3 pos., spring centered- all ports blocked (double pilot) |

See dimensional information for other 543 spools available.