



Spin-on Canister Filters

FEATURES

- ✓ **Easy Filter Replacement:** Line mounted filter with disposable spin-on canisters.
- ✓ **Universal Filter Head:** Filter heads are designed to accept both American and European canister threads.
- ✓ **Water Removal:** In addition to contaminate removable elements, both water and particulate removable canisters are available.

Specifications

Maximum Pressures	Filter Head	175 psi (12 bar) Minimum Burst with 25 psi By-pass Valve†
	Element	60 psi Differential Collapse
Temperature	-15° F to +230° F (Viscosities Permitting)	
Recommended Fluids	Petroleum Based Fluids- ISO VG32-68, Phosphate Ester, Most Vegetable Oils, Water Based Fluids to 40% Water	
Materials	Filter Head	Aluminum
	Filter Element	Absolute- Inorganic Microfiber Nominal- Resin Treated Paper

†CFE6 has 25 psi bypass in the canister element

BYPASS VALVE

In the head, a full-flow bypass valve can be mounted as an option; the bypass flow is designed in such a way that the contaminant is retained in the filter element during bypass conditions.

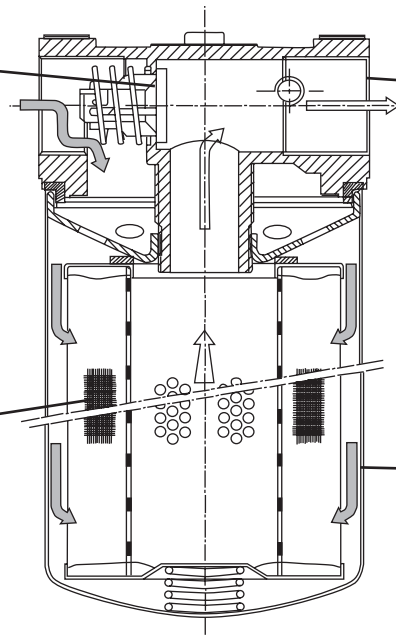

STRONG CONSTRUCTION

The materials and the design ensure a superior resistance to fatigue even at working pressures up to 175 psi (12 bar).

"LONG LIFE" FILTER ELEMENT

The filter elements are designed with a very large filter area giving a high dirt holding capacity.

EASY MAINTENANCE

The spin-on cartridge filter element allows a easy and quick replacement of the element itself.

ORDERING INFORMATION



CANISTER FILTER PART NUMBERING SYSTEM:

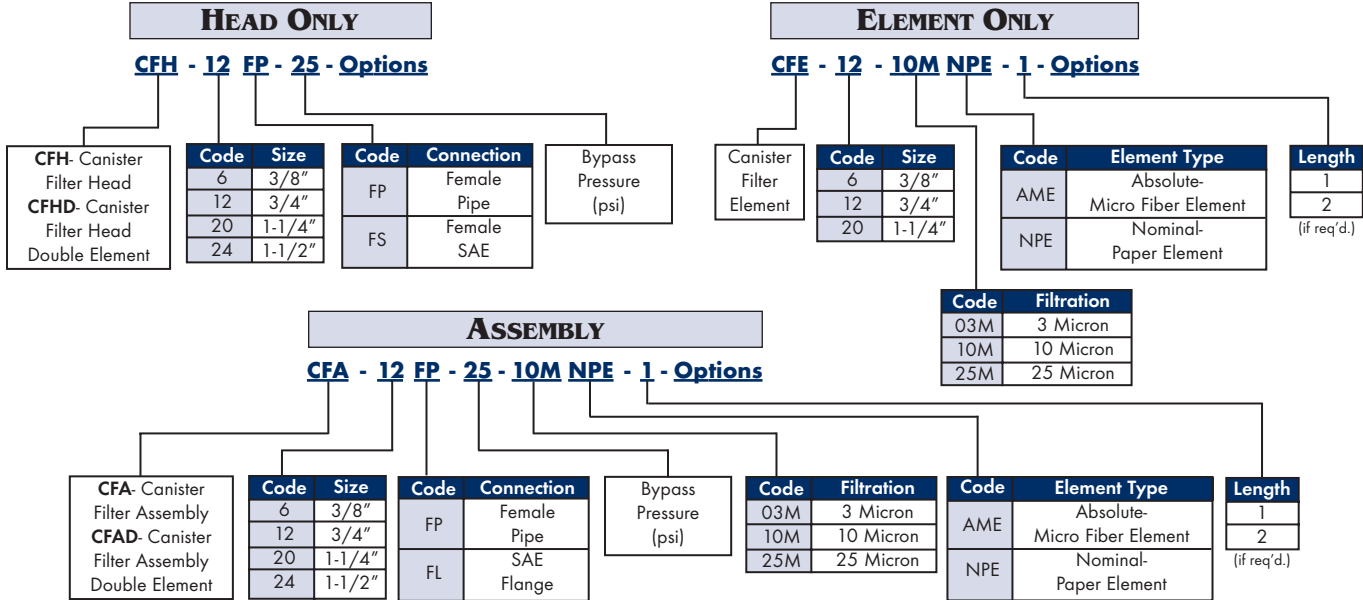

ASSEMBLY	
Visual Indicator	Model # HYV-1, 0-25 psi green/26-50 psi red, 1/8" npt center back mount gauge
Pressure Switch	Model # PS-NO-21, Normally Open- Preset @ 21 psi (increasing) Model # PS-NC-21, Normally Closed- Preset @ 21 psi (increasing) (220 VAC max., 0.5A- resistive, 0.25A- inductive, 100VA- switching power)
Water Removal	Add -WR Suffix to Element or Assembly Part Number, Water Capacity: CFE12-WR= 4.1oz max., CFE20-1-WR= 8.4oz max., CFE20-2-WR= 15.0oz max.



HYV-1 Filter Indicator Gauge

Flow Ratings/Common Models

Thread	Model Number (Head Only)	Filter Rating (microns) $\beta > 75$ Abs./ $\beta > 2$ Nom.	Model Number (Element Only)	Flow* ($\Delta P = 5$ psi)
3/8" NPT	CFH-6FP†	10 μ Nominal	CFE6-10MNPE	3.5
3/4" NPT	CFH-12FP-25	3 μ Absolute	CFE12-03MAME	6
		10 μ Absolute	CFE12-10MAME	10
		10 μ Nominal	CFE12-10MNPE	12
		10 μ Nom./ Water Removal	CFE12-10MNPE-WR	12
		25 μ Nominal	CFE12-25MNPE	12
1-1/4" NPT	CFH-20FP-25	3 μ Absolute	CFE20-03MAME-1	36
		10 μ Absolute	CFE20-10MAME-1	50
		10 μ Nominal	CFE20-10MNPE-1	44
		10 μ Nom./ Water Removal	CFE20-10MNPE-1-WR	44
		3 μ Absolute	CFE20-03MAME-2	46
		10 μ Absolute	CFE20-10MAME-2	57
		10 μ Nominal	CFE20-10MNPE-2	48
		10 μ Nom./ Water Removal	CFE20-10MNPE-2-WR	48
#24 SAE Flange	CFHD-24FL-25 (Two elements required)	3 μ Absolute	CFE20-03MAME-1	60
		10 μ Absolute	CFE20-10MAME-1	72
		10 μ Nominal	CFE20-10MNPE-1	65
		10 μ Nom./ Water Removal	CFE20-10MNPE-1-WR	65
1-1/2" NPT	CFHD-24FP-25 (Two elements required)	3 μ Absolute	CFE20-03MAME-2	71
		10 μ Absolute	CFE20-10MAME-2	79
		10 μ Nominal	CFE20-10MNPE-2	69
		10 μ Nom./ Water Removal	CFE20-10MNPE-2-WR	69

*Element GPM with viscosity of 150 SUS, Specific Gravity of .88 (ISO 32 Oil at 100° F).

†Not available with by-pass/ CFE6 has 25 psi bypass in the canister element

Dimensional Data

Canister Filter Assembly

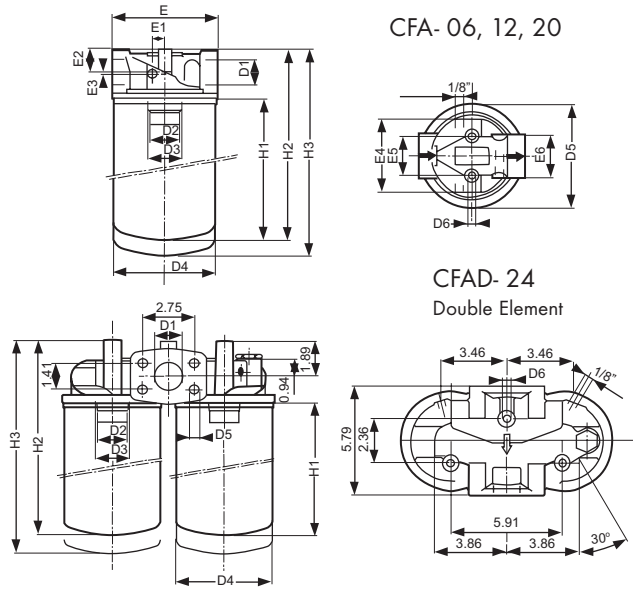

Model Number (Assy- Length)	D1	D2	D3 (Optional thd.)	D4	D5	D6	E	E5	H1	H2	H3	Weight (lbs.)
CFA-6FP	3/8" NPT	3/4"-16 UNF	None	3.0	3.05	1/4"-20 UNC	3.06	1.50	3.50	4.60	5.00	1.0
CFA-12FP	3/4" NPT	1"-12 UNF	None	3.78	3.78	1/4"-20 UNC	3.75	1.50	5.75	7.40	8.19	2.5
CFA-20FP-1	1-1/4" NPT	1-1/2"-16 UN	1-1/4" BSP	5.08	5.28	5/16"-18 UNC	5.25	1.97	6.93	9.49	10.67	3.2
CFA-20FP-2	1-1/4" NPT	1-1/2"-16 UN	1-1/4" BSP	5.08	N/A	5/16"-18 UNC	N/A	N/A	10.71	13.19	14.37	4.0
CFAD-24FL-1	#24 SAE FLG.†	1-1/2"-16 UN	1-1/4" BSP	5.08	N/A	3/8"-16 UNC	N/A	N/A	6.93	10.31	11.68	8.5
CFAD-24FL-2	#24 SAE FLG.†	1-1/2"-16 UN	1-1/4" BSP	5.08	N/A	3/8"-16 UNC	N/A	N/A	10.71	14.06	15.43	10.1
CFAD-24FP-1	1-1/2" NPT	1-1/2"-16 UN	1-1/4" BSP	5.08	N/A	3/8"-16 UNC	N/A	N/A	6.93	10.31	11.68	8.5
CFAD-24FP-2	1-1/2" NPT	1-1/2"-16 UN	1-1/4" BSP	5.08	1/2-13	N/A	N/A	N/A	10.71	14.06	15.43	10.1

†Code 61, 3000 PSI SAE Flange

Units: Inches

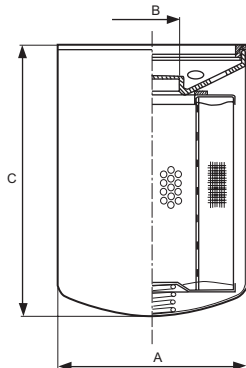

Canister Filter Elements

Model Number (Element- Length)	A	B	C	Nominal Filter Area (Sq. In.)	Absolute Filter Area (Sq. In.)
CFE-6	3.05	3/4"-16 UNF	3.50	75	N/A
CFE-12	3.80	1"-12 UNF	5.75	512	331
CFE-20-1	5.08	1-1/2"-16 UN	6.93	768	615
CFE-20-2	5.08	1-1/2"-16 UN	10.71	1364	1091

Units: Inches