

## MODULAR FILTER, REGULATOR AND LUBRICATOR COMPONENT

Assembled into one Combination Unit



Fully assembled and complete with "L" Type Mounting Brackets (2).

### SPECIFICATIONS

Maximum Supply Pressure	220 psi
Maximum Operating Pressure	145 psi
Ambient & Media Temperature	40°F - 140°F (5°C - 60°C)
Filtration	25 µm
Recommended Oil	5-10 Weight Hydraulic Oil
Bowl Material	Polycarbonate
Metal Bowl Guard*	Zinc
Regulating Range	5 psi - 120 psi
Regulator Construction	Relieving Type

\*No Guard on FRL200

### SYMBOL

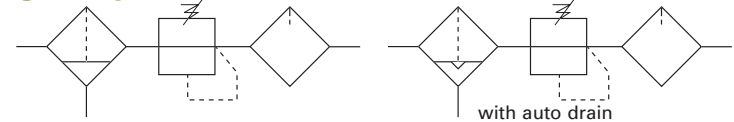

### DIMENSIONAL DATA

Units: mm (inch)

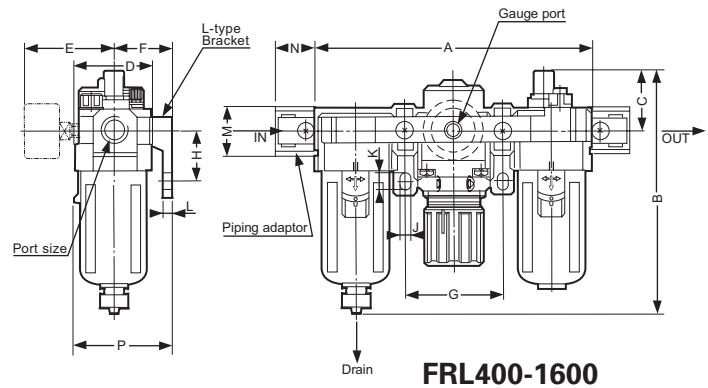
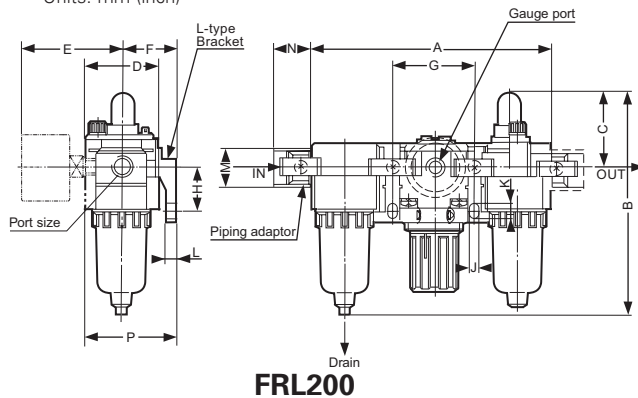

Model	Port Size NPT	A	B	C	D	E	F	G	H	J	K	L	M	N	P	w/ Auto Drain B
		FRL200	1/8" - 1/4"	140.0 (5.51)	125.0 (4.92)	38.1 (1.50)	40.1 (1.57)	56.9 (2.24)	30.0 (1.18)	50.0 (1.97)	23.9 (0.94)	5.6 (0.22)	8.4 (0.33)	5.1 (0.20)	22.1 (0.87)	23.1 (0.91)
FRL400	1/4" - 3/8"	180.9 (7.12)	156.5 (6.16)	38.1 (1.50)	53.1 (2.09)	60.7 (2.39)	40.9 (1.61)	64.0 (2.52)	35.1 (1.38)	7.1 (0.28)	10.9 (0.43)	7.1 (0.28)	34.1 (1.35)	25.9 (1.02)	70.6 (2.78)	194.6 (7.66)
FRL800	1/2"	238.0 (9.37)	191.5 (7.54)	40.9 (1.61)	70.1 (2.76)	65.5 (2.58)	50.0 (1.97)	84.1 (3.31)	39.9 (1.57)	8.9 (0.35)	13.0 (0.51)	7.1 (0.28)	42.2 (1.66)	33.0 (1.30)	87.9 (3.46)	230.4 (9.07)
FRL1600	1"	300.0 (11.81)	271.5 (10.69)	48.0 (1.89)	89.9 (3.54)	75.4 (2.97)	70.1 (2.76)	104.9 (4.13)	50.0 (1.97)	11.9 (0.47)	16.0 (0.63)	9.9 (0.39)	55.1 (2.17)	39.9 (1.57)	115.1 (4.53)	310.4 (12.22)

### ORDERING INFORMATION

#### FRL - 808 - GA

Code	Description	Model	Port Size	Code	Option
FRL	Filter-Regulator-Lubricator	202	1/8"	omit	none
		204	1/4"	A	Auto Drain
		404	1/4"	G	Gauge
		406	3/8"		
		808	1/2"		
		1612	3/4"		
		1616	1"		