

FILTRATION

IN-TANK FILTERS



#8 SAE thru #24 SAE

In Tank Filters



FEATURES

- ✓ **Easy Filter Replacement:** Elements replaced without disrupting plumbing.
- ✓ **No Line Drainage:** In tank filter system reduces wasted oil.
- ✓ **Top Removable Bowl:** Filter bowl can be removed from the top to clean any contaminants when replacing elements.
- ✓ **Less Waste:** Only the element must be discarded.

Specifications

Maximum Pressures	Filter Head	145 psi (10 bar) Minimum Burst with 25 psi By-pass Valve
	Element	Absolute- 145 psi Differential Collapse Nominal- 45 psi Differential Collapse
Temperature		-15° F to +230° F (Viscosities Permitting)
Recommended Fluids		Petroleum Based Fluids- ISO VG32-68, Phosphate Ester, Most Vegetable Oils, Water Based Fluids to 40% Water
Materials	Filter Housing	Aluminum
	Filter Element	Absolute- Inorganic Microfiber w/ Support Nominal- Resin Impregnated Paper

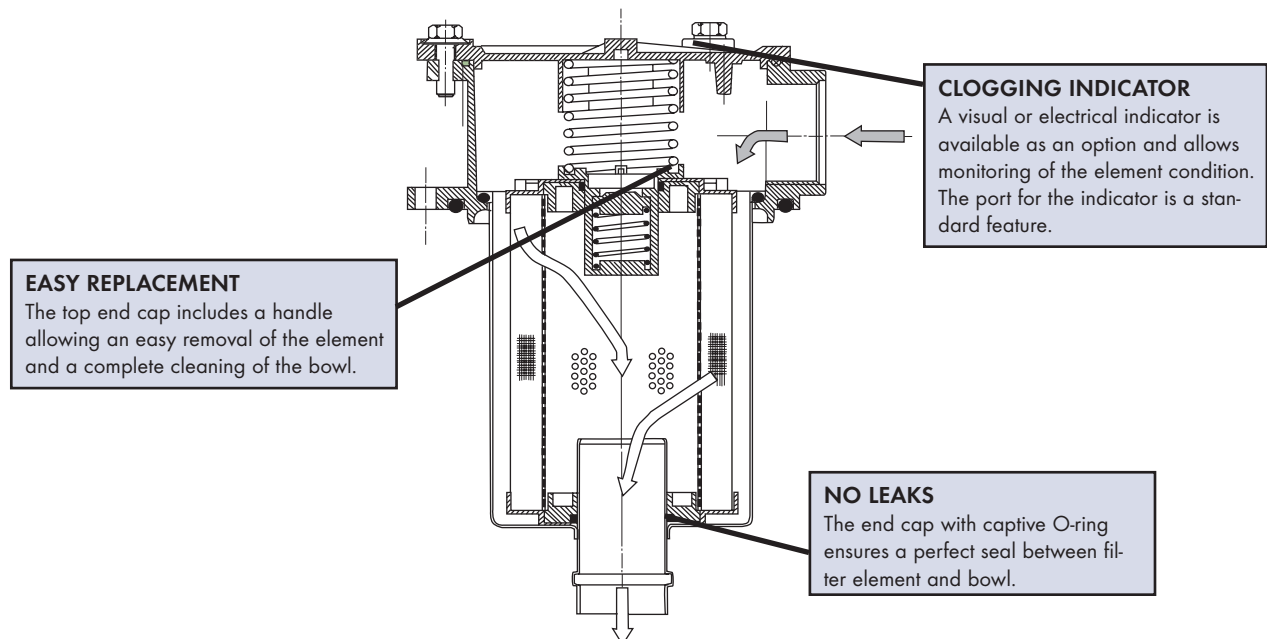

ORDERING INFORMATION



IN-TANK FILTER PART NUMBERING SYSTEM:

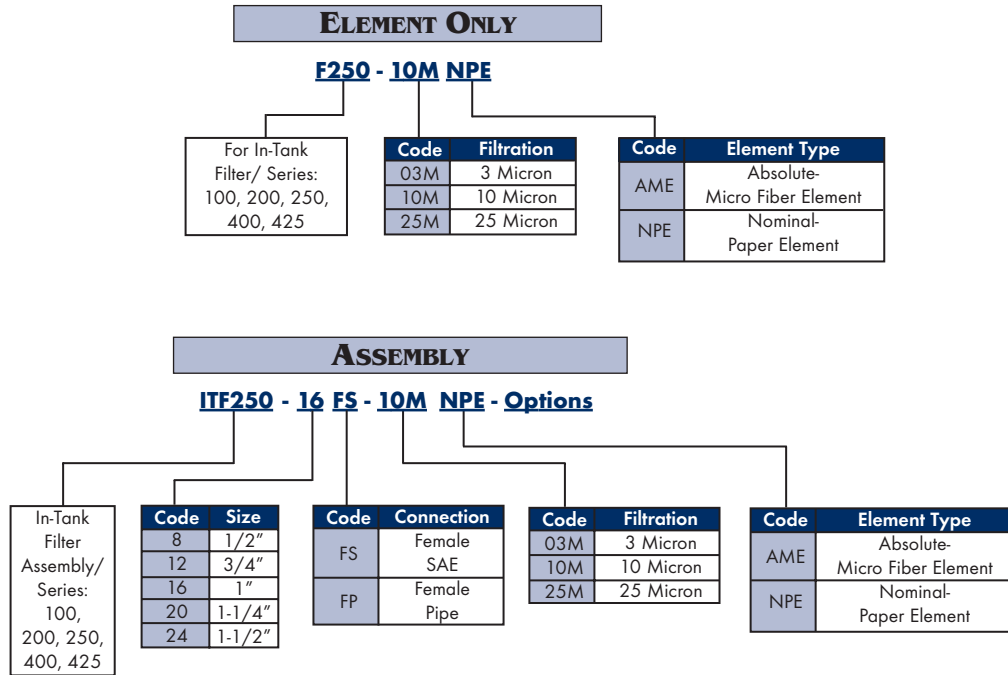

OPTIONAL EQUIPMENT

- Visual Indicator Model # HYV-1, 0-25 psi green/26-50 psi red, 1/8" npt center back mount gauge
- Pressure Switch Model # PS-NO-21, Normally Open- Preset @ 21 psi (increasing)
 Model # PS-NC-21, Normally Closed- Preset @ 21 psi (increasing)
 (220 VAC max., 0.5A- resistive, 0.25A- inductive, 100VA- switching power)



HYV-1 Filter Indicator Gauge

Flow Ratings/Common Models

Thread	Model Number <small>(10 Micron Nominal Assembly)</small>	Filter Rating (microns) $\beta > 75$ Abs./ $\beta > 2$ Nom.	Model Number <small>(Element Only)</small>	Flow* <small>($\Delta P = 5$psi)</small>	Normal Tank Size
#8 SAE (3/4"-16)	ITF100-8FS-10MNPE	3 μ Absolute	F100-03MAME	4.8	3, 5 & 10 gallon
		10 μ Absolute	F100-10MAME	5.5	
		10 μ Nominal	F100-10MNPE	7.9	
#12 SAE (1-1/16"-12)	ITF200-12FS-10MNPE	3 μ Absolute	F200-03MAME	13.2	20 gallon
		10 μ Absolute	F200-10MAME	16.0	
		10 μ Nominal	F200-10MNPE	22.5	
#16 SAE (1-5/16"-12)	ITF250-16FS-10MNPE	3 μ Absolute	F250-03MAME	17.2	35 gallon
		10 μ Absolute	F250-10MAME	24.0	
		10 μ Nominal	F250-10MNPE	34.3	
#24 SAE (1-7/8"-12)	ITF400-24FS-10MNPE	3 μ Absolute	F400-03MAME	63.4	N/A
		10 μ Absolute	F400-10MAME	71.0	
		10 μ Nominal	F400-10MNPE	103.0	
	ITF425-24FS-10MNPE	3 μ Absolute	F425-03MAME	74.0	70- 100 gallon
		10 μ Absolute	F425-10MAME	82.0	
		10 μ Nominal	F425-10MNPE	113.6	

*Element GPM with viscosity of 150 SUS, Specific Gravity of .88 (ISO 32 Oil at 100° F).

Dimensional Data

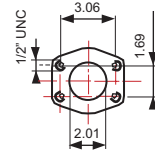
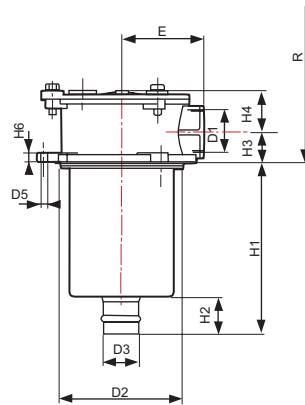

F425-32FL
Optional 2" Flange

In-Tank Filter
Assembly

ITF- 400, 425

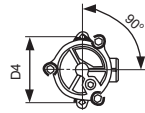

ITF- 100, 200, 250

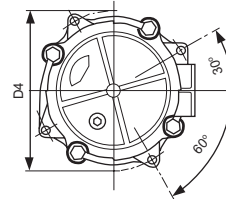

Units: Inches

Model Number	D1	D2	D3	D4	D5	E	H1	H2	H3	H4	H6	"R" Removal Clearance	Weight (lbs.)
ITF100-8FS	#8 SAE	2.60	0.94	3.54	0.26	1.97	3.15	0.98	0.87	1.30	0.35	4.72	1.0
ITF200-12FS	#12 SAE	3.50	1.06	4.53	0.35	2.64	5.79	1.18	1.10	1.85	0.39	7.48	2.0
ITF250-16FS	#16 SAE	3.50	1.57	4.53	0.35	2.64	8.78	1.18	1.10	1.85	0.39	10.63	2.3
ITF400-24FS	#24 SAE	6.83	2.50	8.66	0.41	4.53	9.45	1.97	1.69	2.40	0.51	11.81	7.6
ITF425-24FS	#24 SAE	6.83	2.50	8.66	0.41	4.53	11.22	1.97	1.81	2.40	0.51	13.39	8.7

ITF In Tank Filter Elements

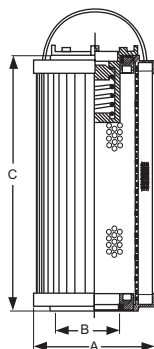

Element Model Number	A	B	C	Nominal Filter Area (Sq. In.)	Absolute Filter Area (Sq. In.)
F100	2.05	0.94	2.76	58	48
F200	2.76	1.10	5.12	248	155
F250	2.76	1.57	8.27	413	257
F300*	3.90	1.57	8.31	663	589
F400	5.12	2.48	7.87	1010	959
F425	5.12	2.48	9.88	1294	1229

*Now obsolete but elements available.

Units: Inches