

PF4 Modular Filters

### FEATURES

- ✓ **3000 Psi Differential Non-Bypass Element:** Element is replaced periodically or if machine speed slows.
- ✓ **Replacable Element:** Element may be easily be replaced by unscrewing end cap. Available in three lengths.
- ✓ **High Quality Glass Fiber Filter Media:** Supported by both support fleece and a stainless steel wire mesh.

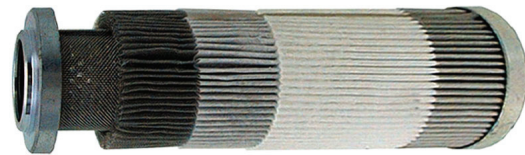

### Specifications

<b>Maximum Pressures</b>	Head & Housing	3,000 psi (210 bar) Maximum Working Pressure
	Element	3,000 psid (210 bar) Minimum Collapsing Pressure
<b>Temperature</b>	-15° F to +230° F (Viscosities Permitting)	
<b>Recommended Fluids</b>	Petroleum Based Fluids- ISO VG32-68, Phosphate Ester, Most Vegetable Oils, Water Based Fluids to 40% Water	
<b>Materials</b>	Filter Heads, Filter Body	Aluminum, Steel
	Filter Element	Glass Fiber ( $\beta_x \geq 200$ ) with Stainless Wire Mesh Support

### Multi-Pass Performance to ISO 4572 Standards

The beta ratio refers to a 16-bar pressure difference.

test duct ACFTD

$$\beta_x = \frac{\text{amount of particles size } > \mu\text{m before filter}}{\text{amount of particles size } > \mu\text{m after filter}}$$

conversion of filtration quotient  $\beta_x$  into filtration efficiency in %

$$\frac{\text{filtration quotient} - 1}{\text{filtration quotient}} \times 100 = \%$$

e.g.  $\beta_{10} = 75 \rightarrow \frac{(75-1)}{75} \times 100 = 98.7\%$

### Glass Fiber

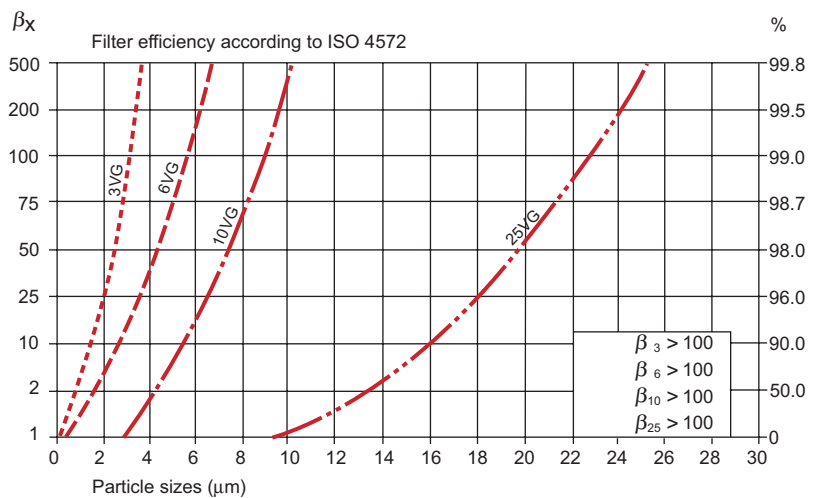

Application	ISO 4406	NAS 1638	Hyvair
Servo valve systems, high pressure circuits, very low flow applications- where silting can occur	13/ 9	3-4	3 $\mu$
Proportional valves	16/13	7-8	10 $\mu$
General heavy industrial, low pressure circuits	19/15	9-11	25 $\mu$

### Element Flow Ratings

Bowl Length	Filter Rating (microns) $\beta_{10} \geq 200$	Model Number (Element Only)	Element Flow*	
			( $\Delta P=10$ psi)	( $\Delta P=20$ psi)
1	3 $\mu$ Absolute	3.4-3	8	17
	10 $\mu$ Absolute	3.4-10	18	37
	25 $\mu$ Absolute	3.4-25	32	60
2	3 $\mu$ Absolute	6.1-3	15	38
	10 $\mu$ Absolute	6.1-10	30	>75
	25 $\mu$ Absolute	6.1-25	61	>75
3	3 $\mu$ Absolute	10.3-3	18	>75
	10 $\mu$ Absolute	10.3-10	44	>75
	25 $\mu$ Absolute	10.3-25	74	>75

\*Element GPM with viscosity of 150 SUS, Specific Gravity of .88 (ISO 32 Oil at 100° F).  
Total pressure drop=  $\Delta P$  Housing +  $\Delta P$  Element

### Filter Housing Pressure Drops

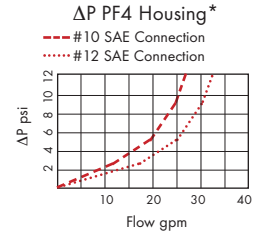
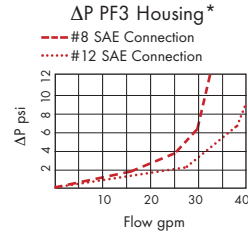

### $\Delta P$ PF9 & PF20 Housing\*

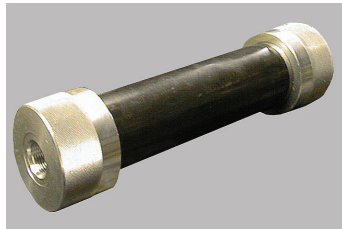
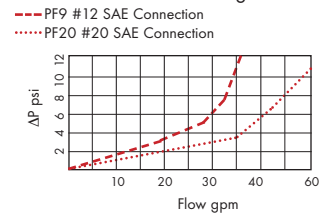

**PF3** In-Line Pressure Filter  
Sizes:  
NPT- 8FP, 12FP, 16FP  
SAE- 8FS, 10FS, 12FS  
No Indicator Available



**PF4** Modular Pressure Filter  
Attaches to Hyvair D03, D05, or D08 Manifolds  
Size:  
10FS female SAE only  
Differential Indicator, Relief Valve, Optional



**PF9** "T" Style Pressure Filter  
Sizes:  
NPT- 8FP, 12FP, 16FP  
SAE- 8FS, 10FS, 12FS  
Differential Indicator, Optional



**PF20** Double "T" Style Pressure Filter  
Sizes:  
NPT- 12FP, 16FP, 20FP  
SAE- 12FS, 16FS, 20FS  
Differential Indicator Optional  
(Uses 2 elements)

## ORDERING INFORMATION

### FILTER ASSEMBLY

**PF4 - 10FS - 10.3 - 3 - D1**

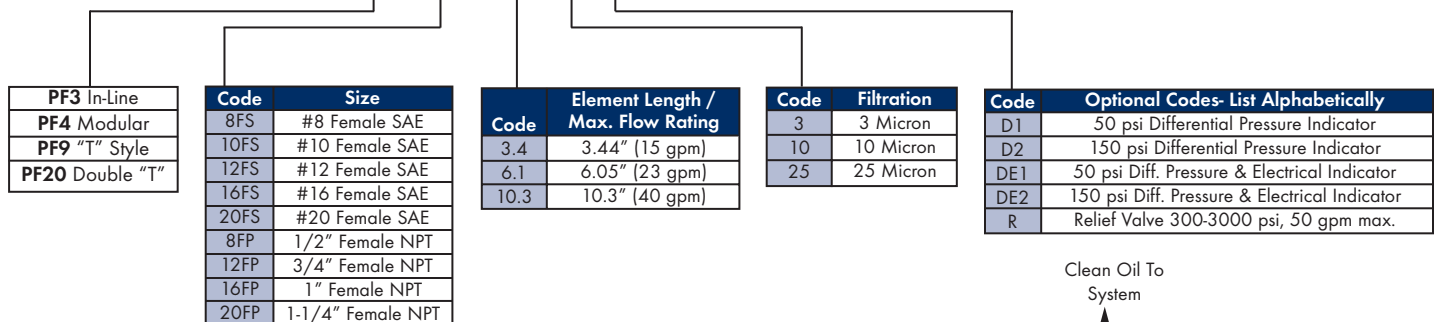

### ELEMENT ONLY

**NB1-S1-14-1.7 - 10.3 - 3**

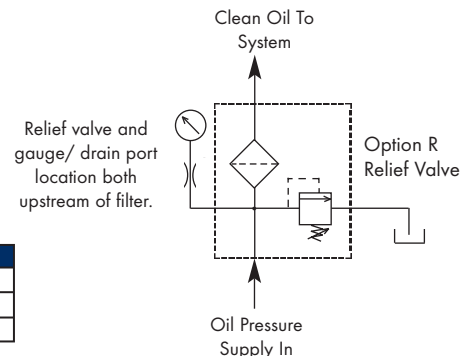
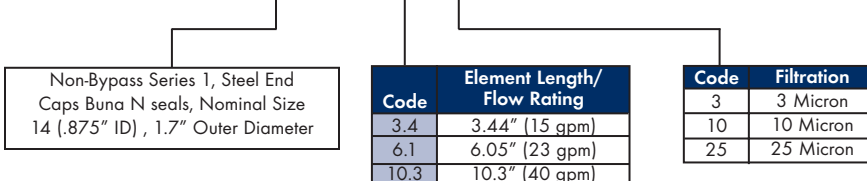

### Dimensional Data



**NB1 Pressure Filter Elements**  
(FOR PF3, PF4, PF9 AND PF20)

Element NB1S1141.7-	C	D	E	3 $\mu$ Dirt Capacity	10 $\mu$ Dirt Capacity	25 $\mu$ Dirt Capacity
3.4-*	3.44	1.7	.875	6.4 g	7.0 g	11.5 g
6.1-*	6.05	1.7	.875	10.6 g	11.6 g	19.0 g
10.3-*	10.3	1.7	.875	15.2 g	16.7 g	27.3 g

Units: Inches

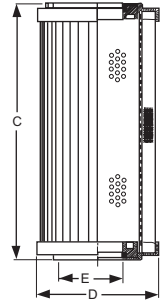

**PF3 Pressure Filter**



Element / Length	A	B (Tube Length)	C
3.4	7.18	4.28	3.44
6.1	9.80	6.90	6.05
10.3	14.07	11.17	10.3

Units: Inches

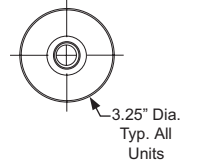
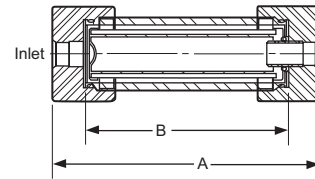

**PF4 Pressure Filter**

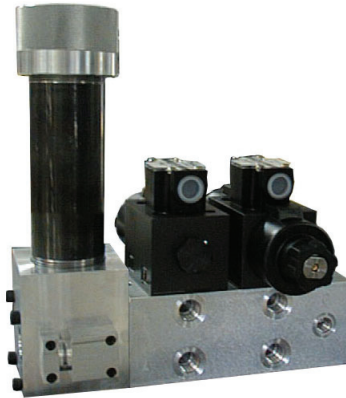
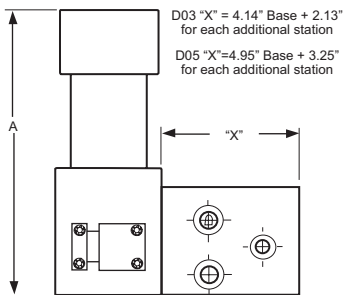
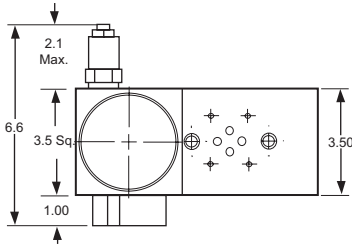

Element / Length	A	B (Tube Length)
3.4	8.26	4.28
6.1	10.88	6.90
10.3	15.15	11.17

Units: Inches

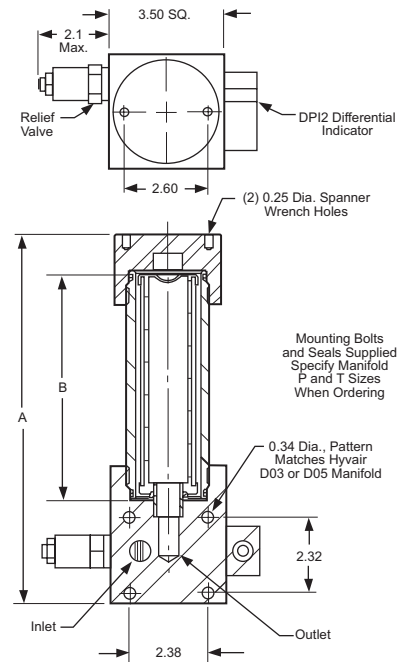

Manifolds (with slight modification) and PF4 pressure filters mounted directly to cylinder.

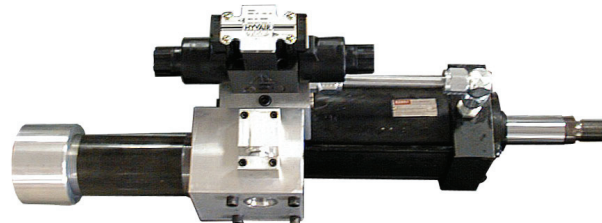
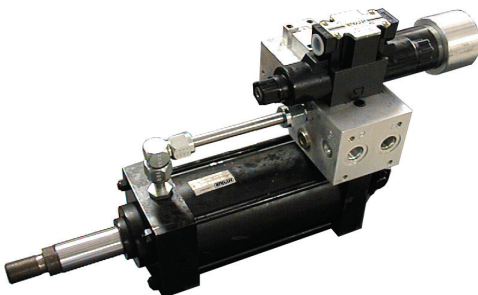

## Dimensional Data

PF9 Pressure Filter

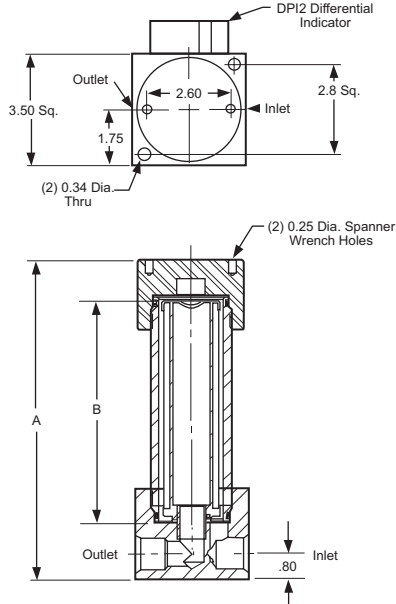

Element / (Act. Length)	A	B (Tube Length)
3.4 (3.44")	7.18	4.28
6.1 (6.05")	9.80	6.90
10.3 (10.3")	14.07	11.17

Units: Inches

PF20 Pressure Filter

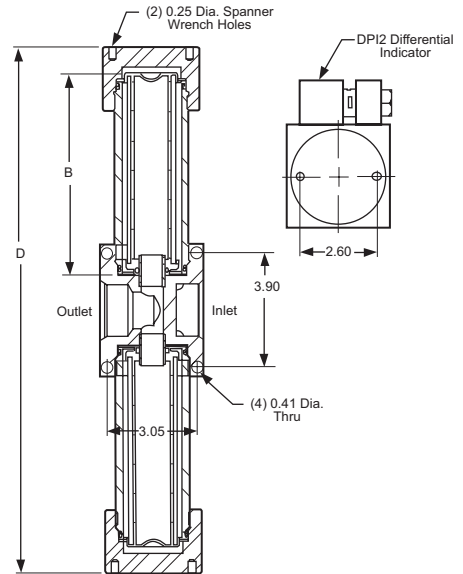

Element / (Act. Length)	D	B (Tube Length)
3.4 (3.44")	12.66	4.28
6.1 (6.05")	17.90	6.90
10.3 (10.3")	26.44	11.17

Units: Inches

## DPI2 Differential Pressure Indicator

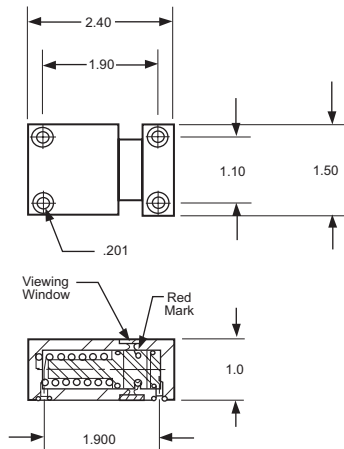

DE1 and DE2 Differential Electric Indicators:  
Available soon.

Differential Indicators:	System Pressure 1000 psi	
	start	dirty
Option Code: <b>D1 (50 psi)</b> Full Model: DPI2-3K-11-A1	$\Delta P = 33$	49
Option Code: <b>D2 (150 psi)</b> Full Model: DPI2-3K-31-A1	$\Delta P = 80$	144