



Fluid Power Pneumatic Division

FRL's

MODULAR AIR PRESSURE REGULATOR



SPECIFICATIONS

Maximum Supply Pressure	220 psi
Maximum Operating Pressure	145 psi
Regulating Range*	5 psi - 120 psi
Ambient & Media Temperature	40°F - 140°F (5°C - 60°C)
Construction	Relieving Type

*Low Pressure Regulating Range: 5-35 psi

SYMBOL

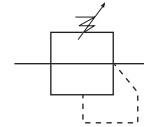

DIMENSIONAL DATA

Units: mm (inch)

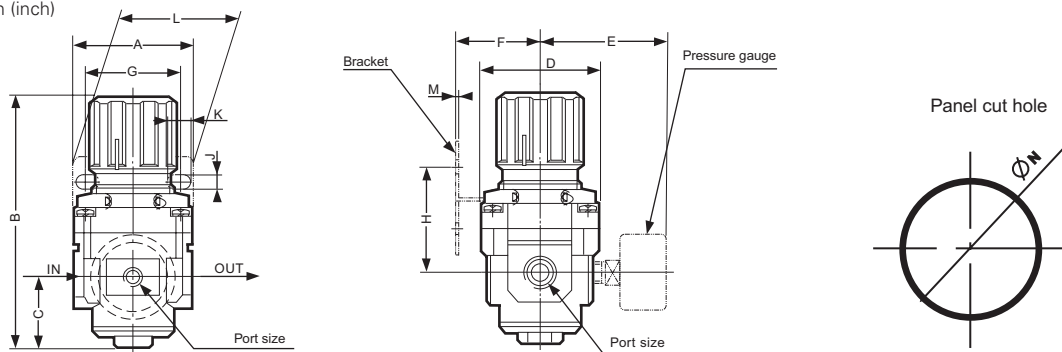

Model	Port Size NPT	A	B	C	D	E	F	G	H	J	K	L	M	N
R200	1/8" - 1/4"	39.9 (1.57)	95.0 (3.74)	17.0 (0.67)	39.9 (1.57)	56.9 (2.24)	30.0 (1.18)	34.0 (1.34)	45.0 (1.77)	5.3 (0.21)	15.5 (0.61)	55.1 (2.17)	2.3 (0.09)	33.5 (1.32)
R400	1/4" - 3/8"	53.3 (2.10)	127.5 (5.02)	35.1 (1.38)	53.3 (2.10)	60.7 (2.39)	40.9 (1.61)	40.1 (1.57)	46.0 (1.81)	6.6 (0.26)	7.9 (0.31)	53.1 (2.09)	2.3 (0.09)	42.4 (1.67)
R800	1/2"	70.1 (2.76)	149.6 (5.89)	37.6 (1.48)	70.1 (2.76)	65.5 (2.58)	50.0 (1.97)	54.1 (2.13)	54.1 (2.13)	8.4 (0.33)	10.4 (0.41)	70.1 (2.76)	2.3 (0.09)	52.6 (2.07)
R1600	3/4" - 1"	89.9 (3.54)	167.9 (6.61)	48.0 (1.89)	89.9 (3.54)	75.4 (2.97)	70.1 (2.76)	66.0 (2.60)	65.8 (2.59)	10.9 (0.43)	13.0 (0.51)	89.9 (3.54)	3.3 (0.13)	52.6 (2.07)

ORDERING INFORMATION

R - 406 - G - Other Options

Code	Description
R	Regulator

Model	Port Size
202	1/8"
204	1/4"
404	1/4"
406	3/8"
808	1/2"
1612	3/4"
1616	1"

Code	Option
omit	none
G	Gauge

*Low Pressure Regulating Range: 5-35 psi



Fluid Power Pneumatic Division

FRL's

MODULAR AIR PRESSURE REGULATOR

SPECIFICATIONS & FLOW DATA Flow and Pressure Data for Regulators and Combination Units

PARTS BREAKDOWN & CONSTRUCTION MATERIAL

No.	Name	Material		
		R200 / FRL200	R400 / FRL400	R800, 1600 / FRL800, 1600
1	Body	Zinc Die Casting	Aluminum Die Casting	
2	Bonnet	Reinforced Nylon		Aluminum Die Casting
3	Diaphragm Assembly	Buna-N		
4	Valve Assembly	Brass & Buna-N		
5	Valve Spring	Stainless Steel		
6	Valve O-Ring	Buna-N		
7	Knob	Reinforced Nylon		
8	O-Ring	Buna-N		
9	O-Ring	Buna-N		

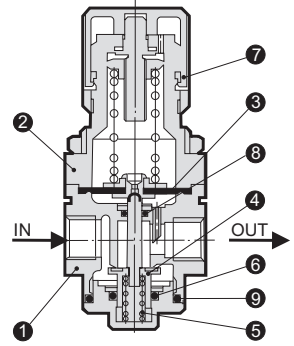

FLOW DATA

Supply Pressure = 100 psi

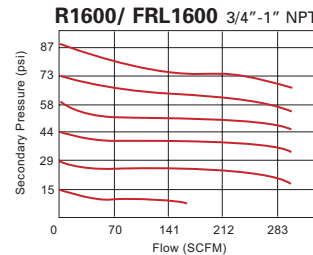
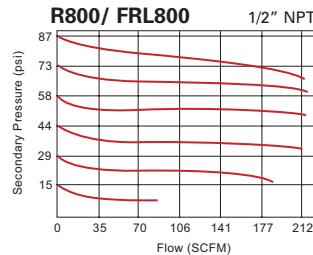
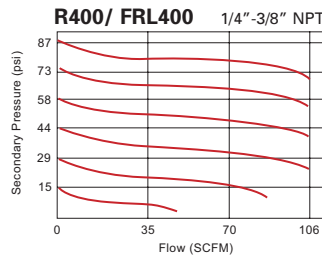
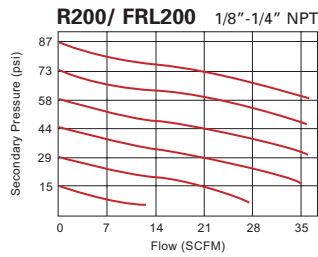

PRESSURE DATA

Supply Pressure = 100 psi Secondary Pressure = 29 psi Flow Rate = .7 SCFM

