

SMALL POWER UNITS

HT SERIES- AC HORIZONTAL TANK



HT Series



HT Series AC Motor

Standard Configuration

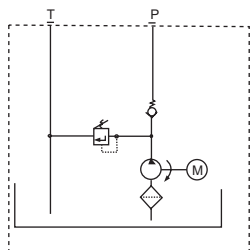

Hyd. Schematic

Ordering Information

HT 2 - 1HP1 - G1.4 - Options

Gallons	HP	Phase	Flow	Option
0.8	1	1	.7	DV
1.3	2	3	1.4	Dump Valve (specify voltage & current type)
2	3		3	D03
			(GPM@1800)	Manifold (specify number of manifold stations & type of circuit: parallel or series)

Rated @ 2500 PSI Max.
Intermittent Duty

"A" SIDE

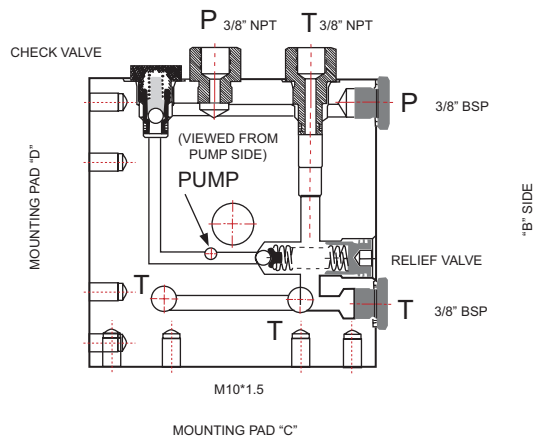

M10*1.5

MOUNTING PAD "C"

With Lowering Valve- DV

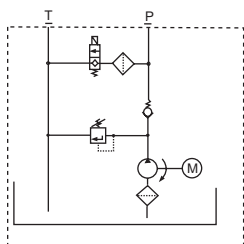

Hyd. Schematic

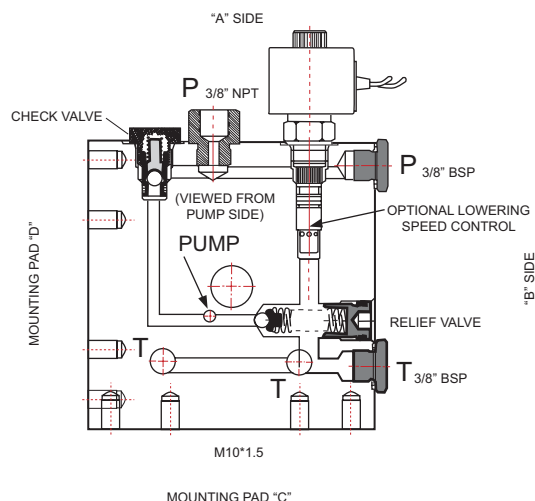

M10*1.5

MOUNTING PAD "C"



SMALL POWER UNITS

HT SERIES- AC HORIZONTAL TANK



HT Series

Dimensional Data .5 thru 3 HP

Units: mm/ inches

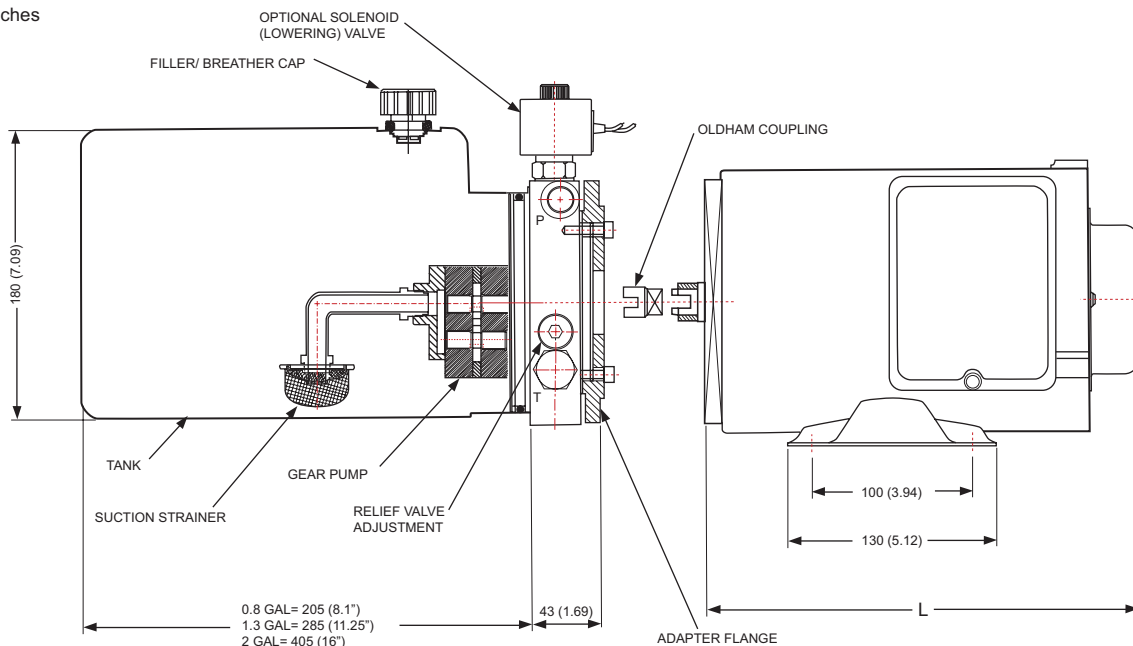

Tank color: Red

Dimensional Data 1 thru 3 HP

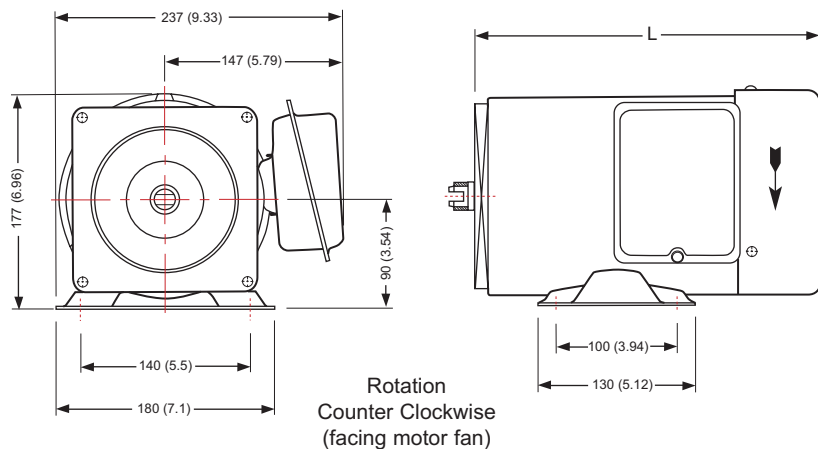

MOTOR	POWER	PHASE	VOLTAGE	HERTZ	"L" DIM
.5HP1	.5HP	1	110/220	60	232 (9.125")
1HP1	1HP	1	110/220	60	280 (11")
1HP3	1HP	3	220/440	60	260 (10.25")
2HP1	2HP	1	110/220	60	300 (11.8")
2HP3	2HP	3	220/440	60	280 (11")
3HP3	3HP	3	220/440	60	300 (11.8")

All motors are rated at 1725 RPM

Dimensional Data .5 HP only

