

SMALL POWER UNITS

VT SERIES- AC VERTICAL TANK



VT Series



VT Series AC Motor

Ordering Information

VT 3 - 2HP1 - G1.4 - Options

HP
1
2
3

Phase
1
3

Flow
.7
1.4
1.9
3.0
3.5
(GPM@1800)

Option
DV
Dump Valve (specify voltage & current type)
D03
Manifold (specify number of manifold stations & type of circuit: parallel or series)

Rated @ 2500 PSI Max.
Continuous Duty

Standard Configuration

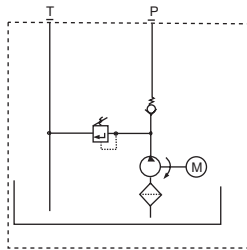

Hyd. Schematic

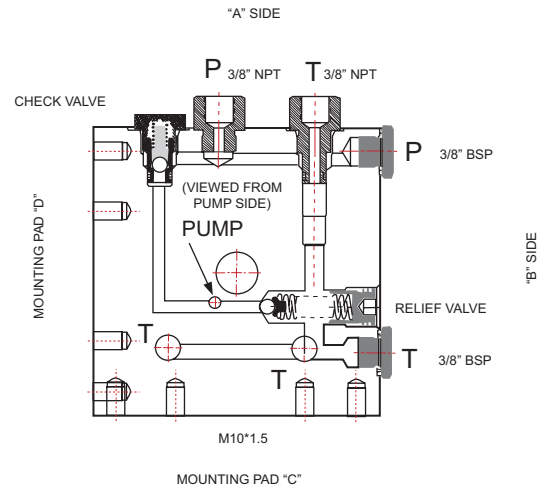

With Lowering Valve- DV

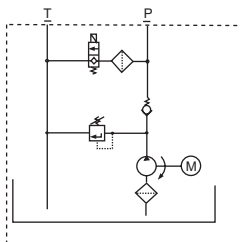

Hyd. Schematic

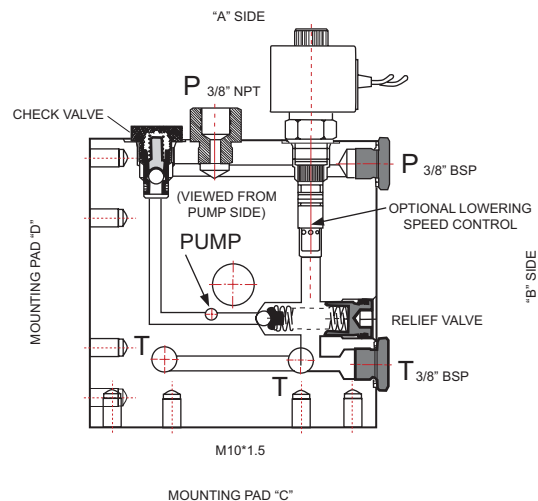

SMALL POWER UNITS

VT SERIES- AC VERTICAL TANK



VT Series

Dimensional Data

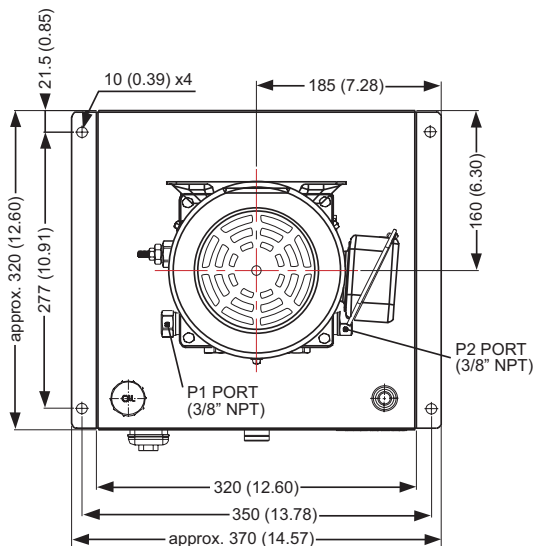
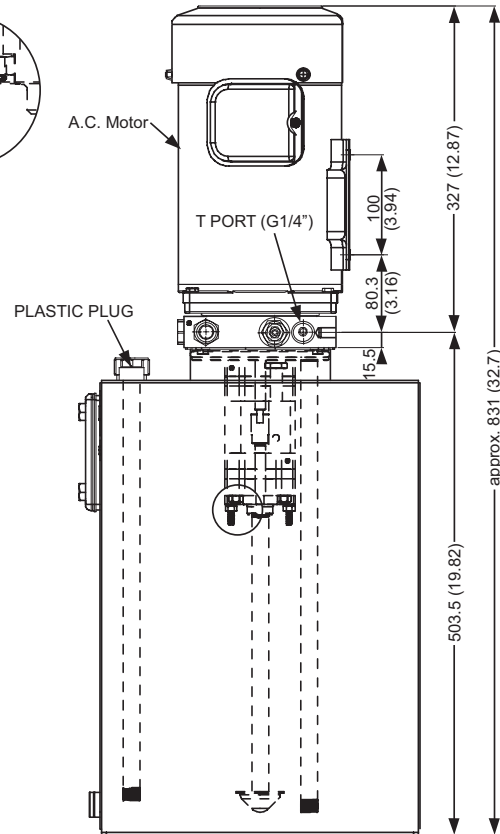
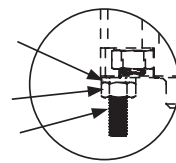
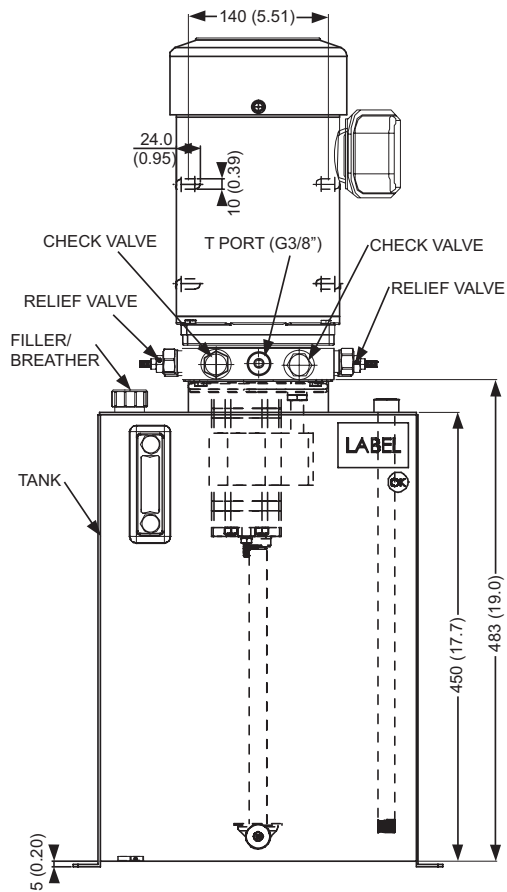

MOTOR	POWER	PHASE	VOLTAGE	HERTZ
1HP1	1HP	1	110/220	60
1HP3	1HP	3	220/440	60
2HP1	2HP	1	110/220	60
2HP3	2HP	3	220/440	60
3HP3	3HP	3	220/440	60

All motors are rated at 1725 RPM

