

MODULAR AIR LINE LUBRICATOR



SPECIFICATIONS

Maximum Supply Pressure	220 psi
Maximum Operating Pressure	145 psi
Ambient & Media Temperature	40°F - 140°F (5°C - 60°C)
Recommended Oil	5-10 Weight Hydraulic Oil
Bowl Material*	Polycarbonate
Metal Bowl Guard**	Zinc

*Metal Bowl is available on all series.

**No Guard on L200.

SYMBOL

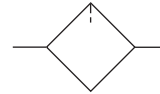

DIMENSIONAL DATA

Units: mm (inch)

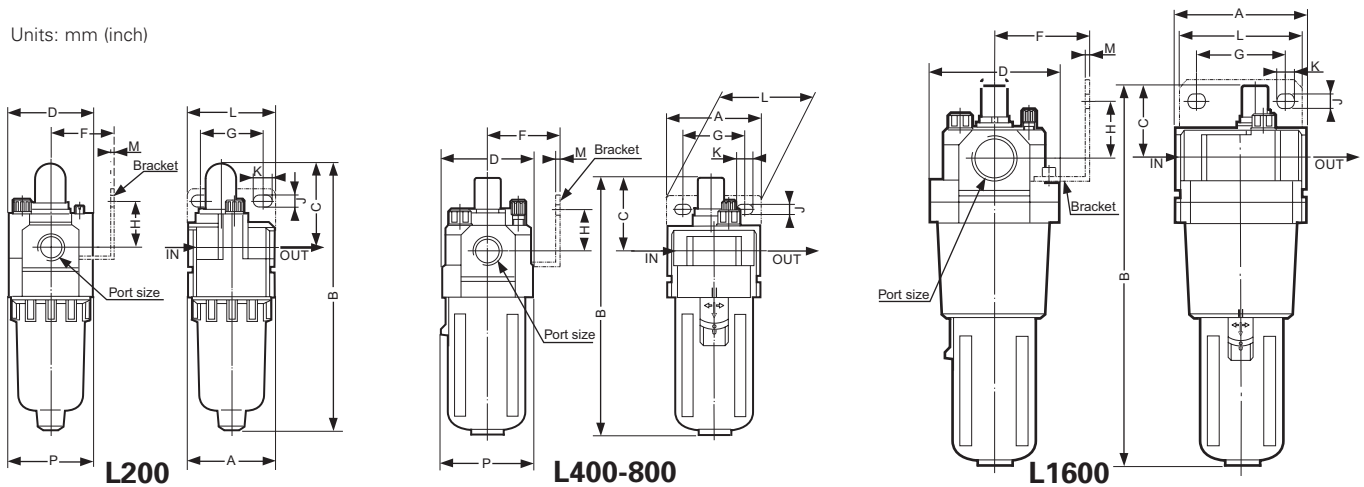

Model	Port Size NPT	A	B	C	D	F	G	H	J	K	L	M	P
L200	1/8" - 1/4"	39.9 (1.57)	121.9 (4.80)	38.1 (1.50)	39.9 (1.57)	30.0 (1.18)	26.9 (1.06)	22.1 (0.87)	5.3 (0.21)	8.4 (0.33)	39.9 (1.57)	2.3 (0.09)	39.9 (1.57)
L400	1/4" - 3/8"	53.3 (2.10)	142.0 (5.59)	38.1 (1.50)	53.3 (2.10)	40.9 (1.61)	40.1 (1.57)	23.1 (0.91)	6.6 (0.26)	7.9 (0.31)	53.1 (2.09)	2.3 (0.09)	55.9 (2.20)
L800	1/2"	70.1 (2.76)	177.0 (6.97)	40.9 (1.61)	70.1 (2.76)	50.0 (1.97)	54.1 (2.13)	25.9 (1.02)	8.4 (0.33)	10.4 (0.41)	70.1 (2.76)	2.3 (0.09)	72.9 (2.87)
L1600	3/4" - 1"	89.9 (3.54)	254.0 (10.00)	45.0 (1.77)	89.9 (3.54)	70.1 (2.76)	66.0 (2.60)	35.1 (1.38)	10.9 (0.43)	13.0 (0.51)	89.9 (3.54)	3.3 (0.13)	89.9 (3.54)

ORDERING INFORMATION

L - 204 - Other Options

Code	Description
L	Lubricator

Model	Port Size
202	1/8"
204	1/4"
404	1/4"
406	3/8"
808	1/2"
1612	3/4"
1616	1"

*Metal Bowl is available on all series.

MODULAR AIR LINE LUBRICATOR

SPECIFICATIONS & FLOW DATA

PARTS BREAKDOWN & CONSTRUCTION MATERIAL

No.	Name	Material		
		L200	L400/ 800	L1600
1	Body	Zinc Die Casting	Aluminum Die Casting	
2	Sight Dome Assem.	Polycarbonate		
3	Plug Assem.	POM (Black)		
4	Retainer Assem.	ABS		
5	Adj. Screw Assem.	ABS		
6	Bowl Assem.	Polycarbonate (With Zinc Bowl Guard)		
7	Bowl O-Ring	Buna-N		
8	Flow Guide	ABS		
9	Housing O-Ring	Buna-N		
10	Housing	---	Aluminum Die Casting	

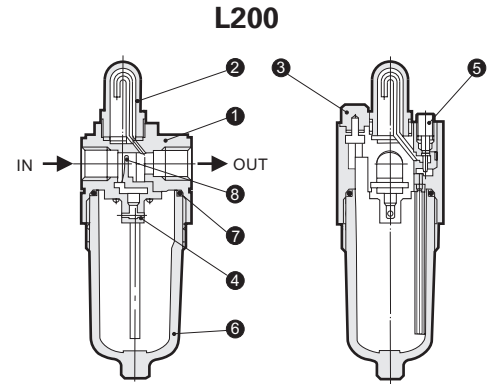

FLOW DATA

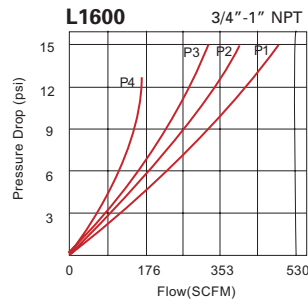
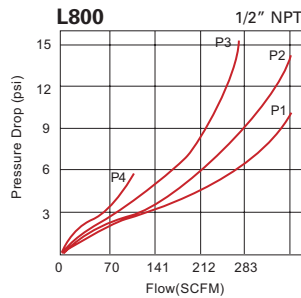
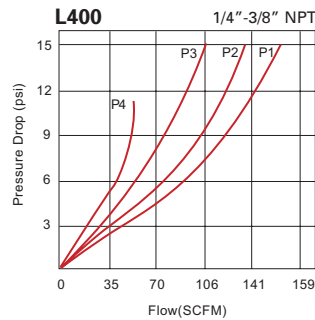
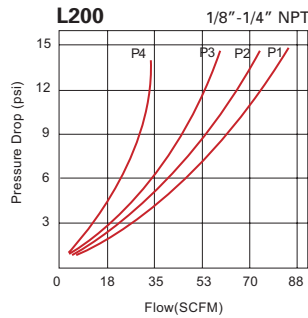

P1 = 100 psi
 P2 = 75 psi
 P3 = 45 psi
 P4 = 15 psi

L400-800

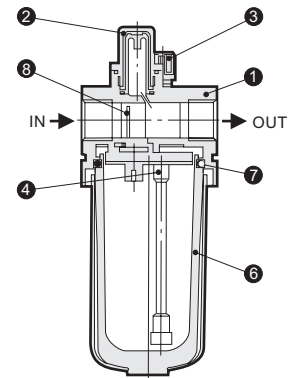

L1600

